

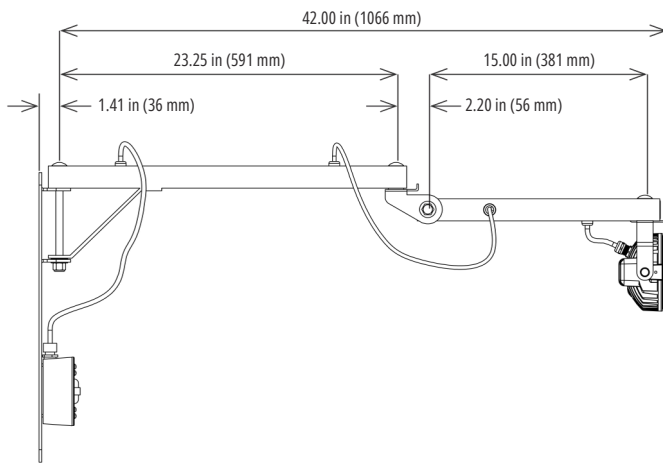

9W wet location light designed to replace up to 150W incandescent light heads  
 Fully illuminates a 53 foot trailer with an even light distribution  
 Durable, compact design to endure accidental impact  
 LED technology increases efficiency, eliminates maintenance and supports green initiatives

### Dimensions

42 inch Arm



60 inch Arm

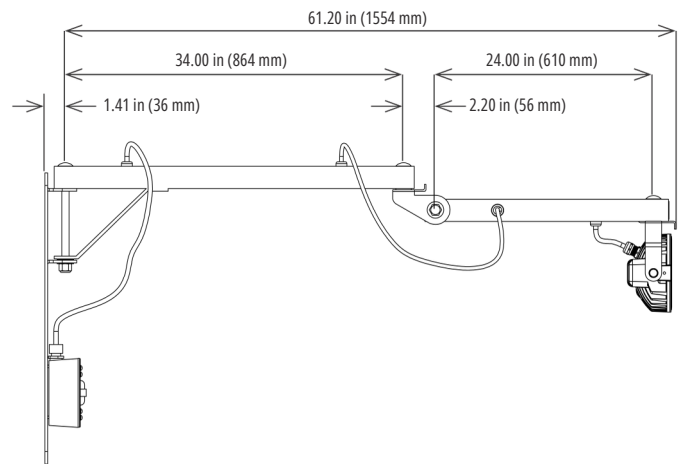

Mounting Plate

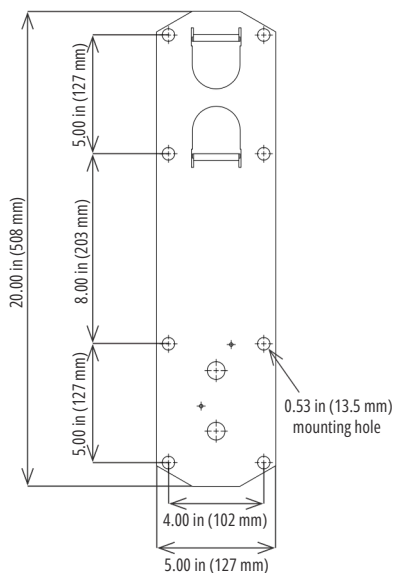

Fixture View

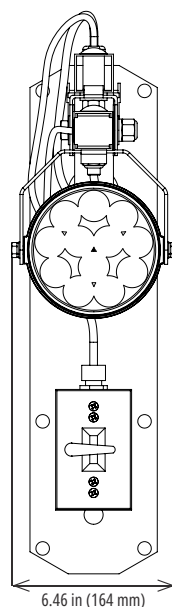

## Specifications

<b>Construction</b>	Marine grade, low-copper content aluminum housing Safety
<b>Finish</b>	yellow powder coat Marine grade (316) stainless steel
<b>Hardware</b>	hardware on light head Zinc plated hardware on arm
<b>Arm</b>	42 or 60 inch available 1.50 in (38 mm) square steel tube arms with wrist-action joint
<b>Lens</b>	Clear impact resistant polycarbonate (CP)
<b>Light source</b>	Osram light emitting diodes (LED) 9W, up to 1200 lumens 25° spot (SP) and 50° flood (FL) optics available CRI ≥ 70 CCT 4000K 50,000 hour rated life
<b>Power source</b>	120V, 60Hz
<b>Wiring</b>	Three-conductor grounded cord from fixture to switch on wall bracket with weather-tight fitting -18°C to +50°C (NS option)
<b>Ambient operating temperature</b>	+5°C to +50°C (standard) Zinc plated steel bracket
<b>Mounting</b>	0.53 inch (13.5 mm) mounting hole clearance 42 inch arm - 30.0 lb (13.6 kg)
<b>Estimated weight</b>	60 inch arm - 36.0 lb (16.3 kg) 5 years
<b>Warranty</b>	

Contact factory for IES files

## Compliances

ETL/cETL Certified to:

- UL 1598 Suitable for Wet Locations
- CSA C22.2 No. 250.0-08

CE (pending)  
IK10 (fixture)  
LM79 and LM80 reports available

## Ordering Information

Example: DLAW2-12LED-SP-42

Fixture	LED Count	Optic	Arm Length	Option
DLAW2	12LED	SP FL	42 60	NS

LED Count	Optic	Arm Length	Option
12LED 12 LEDs, 9W, up to 1200 lumens	SP spot (25°) FL flood (50°)	42 42 inch arm 60 60 inch arm	NS No switch on junction box

Special Projects: We may be able to accommodate your special projects, so please don't hesitate to ask about additional options. Minimum order quantities and/or extended lead times will apply. Contact your Phoenix representative with specific inquiries.

