

High Performance LED Large Area Floodlight

Designed for superior high mast or perimeter lighting

Mounts to any new or existing ring or crossarm

Exceptional output for effective long-distance lighting

Unmatched efficiency with maximum glare control

LED technology increases efficiency, eliminates maintenance and supports green initiatives



Key Applications

Large area lighting
Perimeter lighting
Sports fields
Prisons & correctional facilities
Ports & intermodal terminals
Military bases
Commercial & military airports
Universities
Parking lots

Compliances

UL/cUL Listed to:

- UL 1598 Suitable for Wet Locations
- Complies with CSA C22.2 No. 250.0 and No. 250.13

DLC
IP66

Specifications

Construction	Heavy-duty die-cast aluminum housing
Finish	Gray powder coat
Lens	Advanced free-form optics with multi-scale lenses
Light source	630W and 85,000 lumens - standard CCT 4000K and 5700K CRI>70 Dimmable (0-10V) 120,000 hours at 25°C (L70)
Lifetime	120-277V, 50-60Hz
Power source	200-480V, 50-60Hz
Surge protection	10kA ultra low EMI (integral)
Wiring	1/2 inch cable gland optional power cord
Visor	Visor (V) - standard Extended visor (EV)
EPA (wind load)	1.40 sq. ft.
Ambient operating temperature	-40°C to +55°C
e	Horizontal and vertical rotation 32
Aiming	lbs (14.5 kg) / 64 lbs (29 kg) 5 year
Weight	- standard
Warranty	Extended available warranty options

For IES files, see website or contact factory



CLIR™ Series

High Performance LED Large Area Floodlight



Dimensions

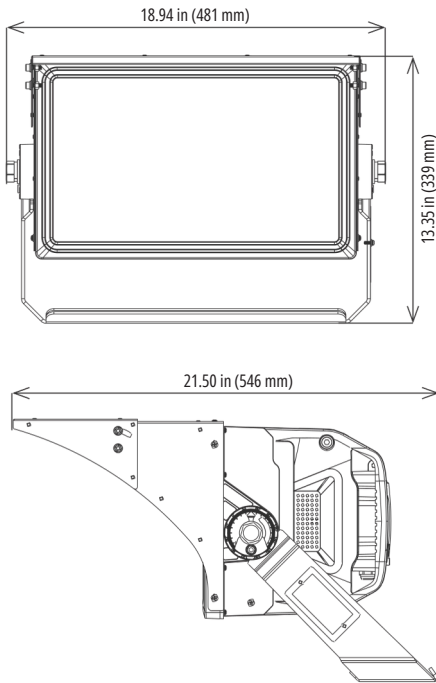

Mounting Bracket

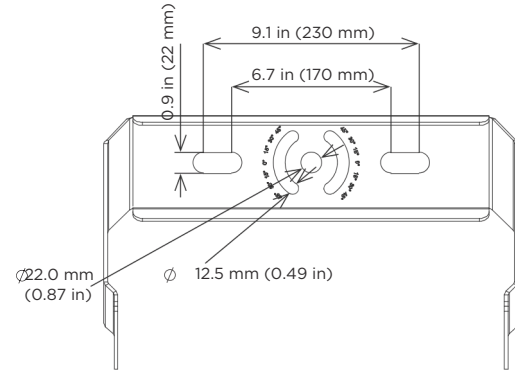

Ordering Information

Example: PL-CLIR-630-NARROW-200-480-4000-V

Fixture	Wattage	Optics	Voltage	CCT	Visor
PL-CLIR	630	NARROW	120-277	4000	V 1
		MEDIUM	200-480	5700	EV

Wattage

630 630W and 85000 lumens

Optics

NARROW Narrow optic
MEDIUM Medium optic

Voltage

120-277 120-277V, 50-60Hz
200-480 200-480V, 50-60Hz

CCT

4000 4000K
5700 5700K

Visor

V 1 Visor - standard
EV Extended visor - 20 inch deep

Notes

1 Indicates standard option for fast delivery

Special Projects: We may be able to accommodate your special projects, so please don't hesitate to ask about additional options. Minimum order quantities and/or extended lead times will apply. Contact your Phoenix representative with specific inquiries.

CLIR™ Series

High Performance LED Large Area Floodlight

PHOENIX[®]
DURABILITY X DESIGN™

Accessories (order separately)

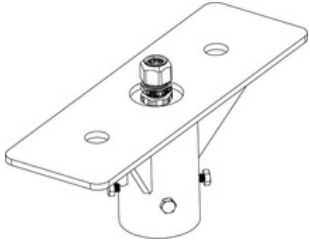

2 3/8 inch Tenon Mount
KIT, CLIR, PTM Pole 2 3/8 inch

